

## TRANSIENT LAMINAR FREE CONVECTION FROM A VERTICAL CONE WITH NON-UNIFORM SURFACE HEAT FLUX

BAPUJI PULLEPUL, J. EKAMBAVANAN, AND I. POP

**Abstract.** In this paper, transient laminar free convection from an incompressible viscous fluid past a vertical cone with non-uniform surface heat flux  $q_w(x) = x^m$  varying as a power function of the distance from the apex of the cone ( $x = 0$ ) is presented. Here  $m$  is the exponent in power law variation of the surface heat flux. The dimensionless governing equations of the flow that are unsteady, coupled and non-linear partial differential equations are solved by an efficient, accurate and unconditionally stable finite difference scheme of Crank-Nicolson type. The velocity and temperature fields have been studied for various parameters such as Prandtl number  $Pr$  and the exponent  $m$ . The local as well as average skin friction and Nusselt number are also presented graphically and discussed in details. The present results are compared with available results from the open literature and are found to be in very good agreement.

### 1. Introduction

Natural convection flows under the influence of gravitational force have been investigated most extensively because they occur frequently in nature as well as in science and engineering applications. When a heated surface is in contact with the fluid, the result of temperature difference causes buoyancy force, which induces the natural convection. Recently heat flux applications are widely using in industries, engineering and science fields. Heat flux sensors can be used in industrial measurement and control systems. Examples of few applications are detection fouling (Boiler

---

Received by the editors: 01.12.2006.

2000 *Mathematics Subject Classification.* 76R10, 80A20.

*Key words and phrases.* Free convection, transient flow, numerical solution.

Fouling Sensor), monitoring of furnaces (Blast Furnace Monitoring/General Furnace Monitoring) and flare monitoring. Use of heat flux sensors can lead to improvements in efficiency, system safety and modeling.

Several authors have developed similarity solutions for two-dimensional axisymmetrical problems for natural convection laminar flow over vertical cone in steady state. Merk and Prins [14, 15] developed the general relation for similar solutions on iso-thermal axis-symmetric forms and they showed that the vertical cone has such a solution in steady state. Further, Hossain et al. [10] have discussed the effects of transpiration velocity on laminar free convection boundary layer flow from a vertical non-isothermal cone and concluded, increase in temperature gradient the velocity as well as the surface temperature decreases. Ramanaiah et al. [25] discussed free convection about a permeable cone and a cylinder subjected to radiation boundary condition. Alamgir [1] has investigated the overall heat transfer in laminar natural convection from vertical cones using the integral method. Pop et al. [20] have studied the compressibility effects in laminar free convection from a vertical cone. Recently, Pop et al. [22] analyzed the steady laminar mixed convection boundary-layer flow over a vertical isothermal cone for fluids of any  $Pr$  for the both cases of buoyancy assisting and buoyancy opposing flow conditions. The resulting non-similarity boundary-layer equations are solved numerically using the Keller-box scheme for fluids of any  $Pr$  from very small to extremely large values ( $0.001 \leq Pr \leq 10000$ ). Takhar et al. [27] discussed the effect of thermo physical quantities on the free convection flow of gases over an isothermal vertical cone in steady-state flow, in which thermal conductivity, dynamic viscosity and specific heat at constant pressure were to be assumed a power law variation with absolute temperature. They concluded that the heat transfer increases with suction and decreases with injection.

Recently theoretical studies on laminar free convection flow over an axisymmetric body have received wide attention especially in case of uniform and non-uniform surface heat flux distributions. Similarity solutions for the laminar free convection from a right circular cone with prescribed uniform heat flux conditions for  $Pr = 0.72, 1, 2, 4, 6, 8, 10$  and  $100$  and were reported by Lin [13] and expressions for

both wall skin friction and wall temperature distributions at  $Pr \rightarrow \infty$  were presented. Na et al. [17, 18] studied the non-similar solutions of the problems for transverse curvature effects of the natural convection flow over a slender frustum of a cone. Later, Na et al. [19] investigated the laminar natural convection flow over a frustum of a cone without transverse curvature effects. In the above investigations the constant wall temperature as well as the constant wall heat flux was considered. The effects of the amplitude of the wavy surfaces associated with natural convection over a vertical frustum of a cone with constant wall temperature or constant wall heat flux was studied by Pop et al. [21]. Gorla et al. [24] presented numerical solution for laminar free convection of power-law fluids past a vertical frustum of a cone without transverse curvature effect (i.e. large cone angles when the boundary layer thickness is small compared with the local radius of the cone).

Further, Pop et al. [23] focused the theoretical study on the effects of suction or injection on steady free convection from a vertical cone with uniform surface heat flux condition. Kumari et al. [12] studied free convection from vertical rotating cone with uniform wall heat flux. Hasan et al. [8] analyzed double diffusion effects in free convection under flux condition along a vertical cone. Hossain et al. [9, 11] studied the non-similarity solutions for the free convection from a vertical permeable cone with non-uniform surface heat flux and the problem of laminar natural convective flow and heat transfer from a vertical circular cone immersed in a thermally stratified medium with either a uniform surface temperature or a uniform surface heat flux. Using a finite difference method, a series solution method and asymptotic solution method, the solutions have been obtained for the non-similarity boundary layer equations.

Many investigations have been done for free convection past a vertical cone/frustum of cone in porous media. Yih [29, 30] studied in saturated porous media combined heat and mass transfer effects over a full cone with uniform wall temperature/concentration or heat/mass flux and for truncated cone with non-uniform wall temperature/variable wall concentration or variable heat/variable mass flux. Recently Chamkha et al. [3] studied the problem of combined heat and mass transfer by natural

convection over a permeable cone embedded in a uniform porous medium in the presence of an external magnetic field and internal heat generation or absorption effects with the cone surface is maintained at either constant temperature or concentration or uniform heat and mass fluxes. Groşan et al. [7] considering the boundary conditions either for a variable wall temperature or variable heat flux studied the similarity solutions for the problem of steady free convection over a heated vertical cone embedded in a porous medium saturated with a non-Newtonian power-law fluid driven by internal heat generation. Wang et al. [28] studied the steady laminar forced convection of micropolar fluids past two-dimensional or axisymmetric bodies with porous walls and different thermal boundary conditions (i.e. constant wall temperature/constant wall heat flux). Further, solutions of the transient free convection flow problems over moving vertical plates and cylinders as well as inclined plates have been obtained by Soundalgekar et al. [26], Muthucumaraswamy et al. [16] and Ganesan et al. [6, 4, 5] using finite difference method.

The present investigation, namely, the transient free convection from a vertical cone with non-uniform surface heat flux has not received any attention. Hence, the present work is considered to deal with transient free convection over a vertical cone with non-uniform surface heat flux. The governing boundary layer equations are solved by an implicit finite-difference scheme of Crank-Nicolson type with various parameters  $Pr$  and  $m$ . In order to check the accuracy of our numerical results, the present results are compared with the available results of Hossain and Paul [9] for non-uniform surface heat flux and Lin [13] for uniform heat flux and are found to be in excellent agreement.

## 2. Mathematical analysis

We consider the axisymmetric transient laminar free convection of a viscous and incompressible fluid of uniform ambient temperature  $T'_\infty$  past a vertical cone with non-uniform surface heat flux. It is assumed that the viscous dissipation effects are negligible. It is assumed that initially ( $t' \leq 0$ ), the cone surface and the surrounding fluid that are at rest. Then at time  $t' > 0$ , it is assumed that heat is supplied from

cone surface to the fluid at the rate  $q_w(x) = x^m$  and it is maintained at this value with  $m$  being a constant. The co-ordinate system is chosen (as shown in Fig.1) such that  $x$  measures the distance along the surface of the cone from the apex ( $x = 0$ ) and  $y$  measures the distance normally outward, respectively. Here,  $\phi$  is the semi vertical angle of the cone and  $r$  is the local radius of the cone. The fluid properties are assumed to be constant except for density variations, which induce buoyancy force term in the momentum equation. The governing boundary layer equations of continuity, momentum and energy under Boussinesq approximation with the viscous dissipation effect neglected are as follows:

- continuity

$$\frac{\partial}{\partial x}(ru) + \frac{\partial}{\partial y}(ru) = 0, \quad (1)$$

- momentum

$$\frac{\partial u}{\partial t'} + u \frac{\partial u}{\partial x} + v \frac{\partial u}{\partial y} = g\beta(T' - T'_\infty) \cos \phi + \nu \frac{\partial^2 u}{\partial y^2}, \quad (2)$$

- energy

$$\frac{\partial T'}{\partial t'} + u \frac{\partial T'}{\partial x} + v \frac{\partial T'}{\partial y} = \alpha \frac{\partial^2 T'}{\partial y^2}. \quad (3)$$

The initial and boundary conditions are

$$\begin{aligned} t' \leq 0 : u = 0, v = 0, T' = T'_\infty \text{ for all } x \text{ and } y, \\ t' > 0 : u = 0, v = 0, \frac{\partial T'}{\partial y} = \frac{-q_w(x)}{k} \text{ at } y = 0, \\ u = 0, T' = T'_\infty \text{ at } x = 0, \\ u \rightarrow 0, T' \rightarrow T'_\infty \text{ as } y \rightarrow \infty \end{aligned} \quad (4)$$

where  $u$  and  $v$  are the velocity components along  $x$ - and  $y$ - axes,  $T'$  is the fluid temperature,  $t'$  is the time,  $g$  is the acceleration due to gravity,  $r$  is the local radius of the cone,  $k$  is the thermal conductivity of the fluid,  $\alpha$  is the thermal diffusivity,  $\beta$  is the thermal expansion coefficient, semi-vertical angle of the cone and  $\nu$  is the kinematic viscosity.

The physical quantities of interest are the local skin friction  $\tau_x$  and the local Nusselt number  $Nu_x$  which are given, respectively, by

$$\tau_x = \mu \left( \frac{\partial u}{\partial y} \right)_{y=0}, \quad Nu_x = \frac{x}{(T'_w - T'_\infty)} \left( -\frac{\partial T'}{\partial y} \right)_{y=0} \quad (5)$$

where  $\mu$  is the dynamic viscosity. Also, the average skin friction  $\bar{\tau}_L$  and the average heat transfer coefficient  $\bar{h}$  over the cone surface are given by

$$\bar{\tau}_L = \frac{2\mu}{L^2} \int_0^L x \left( \frac{\partial u}{\partial y} \right)_{y=0} dx, \quad \bar{h} = \frac{2k}{L^2} \int_0^L \frac{x}{(T'_w - T'_\infty)} \left( -\frac{\partial T'}{\partial y} \right)_{y=0} dx \quad (6)$$

The average Nusselt number is then given by

$$\overline{Nu}_L = \frac{L\bar{h}}{k} = \frac{2}{L} \int_0^L \frac{x}{(T'_w - T'_\infty)} \left( -\frac{\partial T'}{\partial y} \right)_{y=0} dx \quad (7)$$

Further, we introduce the following non-dimensional variables:

$$X = \frac{x}{L}, \quad Y = \frac{y}{L} Gr^{1/5}, \quad t = \left( \frac{\nu}{L^2} Gr^{2/5} \right) t', \quad R = \frac{r}{L}, \quad (8)$$

$$U = \left( \frac{L}{\nu} Gr^{-2/5} \right) u, \quad V = \left( \frac{L}{\nu} Gr^{-1/5} \right) v, \quad T = \frac{(T' - T'_\infty)}{(q_w(L)L/k)} Gr_L^{1/5},$$

where  $Gr_L = g\beta(q_w L/k)L^4 \cos \phi / \nu^2$  is the Grashof number based on the reference length  $L$ ,  $Pr = \nu/\alpha$  is the Prandtl number and  $r = x \sin \phi$ . Equations (1), (2) and (3) can then be written in the following non-dimensional form:

$$\frac{\partial}{\partial X}(RU) + \frac{\partial}{\partial Y}(RV) = 0, \quad (9)$$

$$\frac{\partial U}{\partial t} + U \frac{\partial U}{\partial X} + V \frac{\partial U}{\partial Y} = T + \frac{\partial^2 U}{\partial Y^2}, \quad (10)$$

$$\frac{\partial T}{\partial t} + U \frac{\partial T}{\partial X} + V \frac{\partial T}{\partial Y} = \frac{1}{Pr} \frac{\partial^2 T}{\partial Y^2}, \quad (11)$$

where  $Pr$  is the Prandtl number and  $R$  is the dimensionless radius of the cone. The corresponding non-dimensional initial and boundary conditions (4) become

$$\begin{aligned} t \leq 0: \quad & U = 0, \quad V = 0, \quad T = 0 \text{ for all } X \text{ and } Y \\ t > 0: \quad & U = 0, \quad V = 0, \quad \frac{\partial T}{\partial Y} = -X^m \text{ at } Y = 0 \\ & U = 0, \quad T = 0 \quad \text{at } X = 0 \\ & U \rightarrow 0, \quad T \rightarrow 0 \quad \text{as } Y \rightarrow \infty \end{aligned} \quad (12)$$

The local non-dimensional skin friction  $\tau_X$  and the local Nusselt number  $Nu_X$  given by (5) become

$$\tau_X = Gr_L^{3/5} \left( \frac{\partial U}{\partial Y} \right)_{Y=0}, \quad Nu_X = \frac{Gr_L^{1/5}}{T_{Y=0}} X^{m+1} \quad (13)$$

Also, the non-dimensional average skin-friction  $\bar{\tau}$  and the average Nusselt number  $\bar{Nu}$  are reduced to

$$\bar{\tau} = 2Gr_L^{3/5} \int_0^1 X \left( \frac{\partial U}{\partial Y} \right)_{Y=0} dX, \quad \bar{Nu} = 2Gr_L^{1/5} \int_0^1 \frac{X^{m+1}}{(T)_{Y=0}} dX. \quad (14)$$

### 3. Solution procedure

The unsteady, non-linear, coupled and partial differential Equations (9), (10) and (11) with the initial and boundary conditions (12) are solved by employing a finite-difference scheme of Crank-Nicolson type. The finite-difference scheme of dimensionless governing equations is reduced to tri-diagonal system of equations and is solved by Thomas algorithm as discussed in Carnahan et al. [2]. The region of integration is considered as a rectangle with  $X_{max} = 1$  and  $Y_{max} = 26$  where  $Y_{max}$  corresponds to  $Y_\infty$ , which lies very well out side both the momentum and thermal boundary layers. The maximum of  $Y$  was chosen as 26, after some preliminary investigation so that the last two boundary conditions of (12) are satisfied within the tolerance limit  $10^{-5}$ . After experimenting with a few sets of mesh sizes, the mesh sizes have been fixed as  $\Delta X = 0.05$ ,  $\Delta Y = 0.05$  with time step  $\Delta t = 0.01$ . The scheme is unconditionally stable. The local truncation error is  $O(\Delta t^2 + \Delta Y^2 + \Delta X)$  and it tends to zero as  $\Delta t$ ,  $\Delta Y$  and  $\Delta X$  tend to zero. Hence, the scheme is compatible. Stability and compatibility ensure the convergence.

### 4. Results and discussion

In order to prove the accuracy of our numerical results, the present results in steady state at  $X = 1.0$  are compared with available similarity solutions in literature. The velocity and temperature profiles of cone with uniform surface heat flux when  $Pr = 0.72$  are displayed in Fig.2 and the numerical values of local skin-friction  $\tau_X$  and local Nusselt number  $Nu_X$ , for different values of Prandtl number shown in Table

1 are compared with similarity solutions of Lin [13] in steady state using a suitable transformation (i.e.  $Y = (20/9)^{1/5}\eta$ ,  $T = (20/9)^{1/5}[-\theta(0)]$ ,  $U = (20/9)^{1/5}f'(\eta)$ ,  $\tau_X = (20/9)f''(0)$ ), where  $\eta$  is the similarity variable,  $f'(\eta)$  is the velocity profile and  $f''(0)$  is the reduced skin friction, which are defined in [13]. In addition, the local skin-friction  $\tau_X$  and the local Nusselt number  $Nu_X$  for different values of Prandtl number when heat flux gradient  $m = 0.5$  at  $X = 1.0$  in steady state are compared with the non-similarity results of Hossain and Paul [9] in Table 2 given as  $F_0''(0)$ . It is observed that the results are in good agreement with each other. We also noticed that the present results agree well with those of Pop and Watanabe [23] (see Table 1)

In Figs.3-6, transient velocity and temperature profiles are shown at  $X = 1.0$ , with various parameters  $Pr$  and  $m$ . The value of  $t$  with star (\*) symbol denotes the time taken to reach the steady-state flow. In Figs.3 and 4, transient velocity and temperature profiles are plotted for various values of  $Pr$  and  $m = 0.25$ . Increasing  $Pr$  means that the viscous force increases and thermal diffusivity reduces, which causes a reduction in the velocity and temperature, as expected. It is also noticed that the time taken to reach steady-state flow increases and thermal boundary layer thickness reduces with increasing  $Pr$ . Further, it is clear seen from Fig.3 that the momentum boundary layer thickness increases with the increase of  $Pr$  from unity. In Figs.5 and 6, transient velocity and temperature profiles are shown for various values of  $m$  with  $Pr = 1.0$ . Impulsive forces are reduced along the surface of the cone near the apex for increasing values of  $m$  (i.e. the gradient of heat flux along the cone near the apex reduces with the increasing values of  $m$ ). Due to this, the difference between temporal maximum values and steady-state values reduces with increasing  $m$ . It is also observed that increasing in  $m$  reduces the velocity as well as temperature and takes more time to reach steady-state.

The study of the effects of the parameters on local as well as the average skin-friction, and the rate of heat transfer is more important in heat transfer problems. The derivatives involved in Eqs. (13) and (14) are obtained using five-points approximation formula and then the integrals are evaluated using Newton-Cotes closed integration formula. The variation of the local skin-friction  $\tau_X$  and the local Nusselt number



$Nu_X$  in the transient period at various positions on the surface of the cone ( $X = 0.25$  and  $1.0$ ) for different values of  $m$ , are shown in Figs.7 and 8. It is observed from Fig.7 that the local skin-friction decreases with increasing  $m$  and the effect of  $m$  over the local skin-friction  $\tau_X$  is more near the apex of the cone and reduces gradually with increasing the distance along the surface of the cone from the apex. From Fig.8, it is noticed that near the apex, local Nusselt number  $Nu_X$  reduces with increasing  $m$ , but that trend is slowly changed and reversed as distance increases along the surface from apex. The variation of the local skin-friction  $\tau_X$  and the local Nusselt number  $Nu_X$  in the transient regime is displayed in Figs.9 and 10 for different values of  $Pr$  and at various positions on the surface of the cone ( $X = 0.25$  and  $1.0$ ). It is clear from these figures that the local skin frictions  $\tau_X$  reduces and the local Nusselt number increases with the increasing  $Pr$ , these effects gradually increase in the transient period with increasing the distance along the cone surface from the apex. The influence of  $m$  on average skin-friction  $\bar{\tau}$  is more when  $m$  is reduced as it can be seen in Fig.11. Finally, Fig.12 displays the influence of  $Pr$  and  $m$  on the average Nusselt number  $\overline{Nu}$  in the transient period. This shows that there is no significant influence of  $m$  over the average Nusselt number. Average Nusselt number  $\overline{Nu}$  increases with increasing  $Pr$ .

## 5. Conclusions

A numerical study has been carried out for the transient laminar free convection from a vertical cone subjected to a non-uniform surface heat flux. The dimensionless governing boundary layer equations are solved numerically using an implicit finite-difference method of Crank-Nicolson type. Present results are compared with available results from the literature and are found to be in good agreement. The following conclusions are made:

1. The time taken to reach steady-state increases with increasing  $Pr$  or  $m$ .
2. The difference between temporal maximum values and steady state values (for both velocity and temperature) becomes less when  $Pr$  or  $m$  increases.
3. The influence of  $m$  over the local skin friction  $\tau_X$  is large near the apex of the cone and that reduces slowly with increasing distance from it.

4. In transient period, the local Nusselt number reduces with increasing  $m$  near the apex but that trend is changed and reversed as the distance increases from it.
5. The influence of  $Pr$  on the local skin-friction  $\tau_X$  and the local Nusselt number  $Nu_X$  increases along the surface from the apex.
6. The average skin-friction  $\bar{\tau}$  decreases with increasing  $m$  and the effect of  $m$  on average Nusselt number  $\bar{Nu}$  is almost negligible.

Table 1. Comparison of steady state local skin-friction and temperature values at  $X = 1.0$  with those of Lin [13] for uniform surface heat flux

$Pr$	Temperature			Local skin friction		
	Lin [13]		Present results	Lin [13]		Present results
	$-\theta(0)$	$-\left(\frac{20}{9}\right)^{1/5} \theta(0)$	$T$	$f''(0)$	$\left(\frac{20}{9}\right)^{2/5} f''(0)$	$\tau_X$
0.72	1.52278 <sup>1</sup>	1.7864	1.7714	0.22930 <sup>1</sup>	1.224	1.2105
1	1.39174	1.6327	1.6182	0.78446	1.0797	1.0669
2	1.16209	1.3633	1.3499	0.60252	0.8293	0.8182
4	0.98095	1.1508	1.1385	0.46307	0.6373	0.6275
6	0.89195	1.0464	1.0344	0.39688	0.5462	0.5371
8	0.83497	0.9796	0.9677	0.35563	0.4895	0.4808
10	0.79388	0.9314	0.9196	0.32655	0.4494	0.4411
100	0.48372	0.5675	0.5531	0.13371	0.184	0.1778

<sup>1</sup> Values taken from Pop and Watanabe [23] when suction/injection is zero.

Table 2. Comparison of steady state local skin-friction and local Nusselt number values at  $X = 1.0$  with those of Hossain and Paul [9] for different values of  $Pr$  when  $m = 0.5$

$Pr$	Local skin-friction		Local Nusselt number	
	Results [9] $F_0''(0)$	Present results $\tau_X/Gr_L^{3/5}$	Results [9] $1/\phi_0(0)$	Present results $Nu_X/Gr_L^{1/5}$
0.01	5.13457	5.1388	0.14633	0.1463
0.05	2.93993	2.9352	0.26212	0.2634
0.1	2.29051	2.2853	0.33174	0.3332

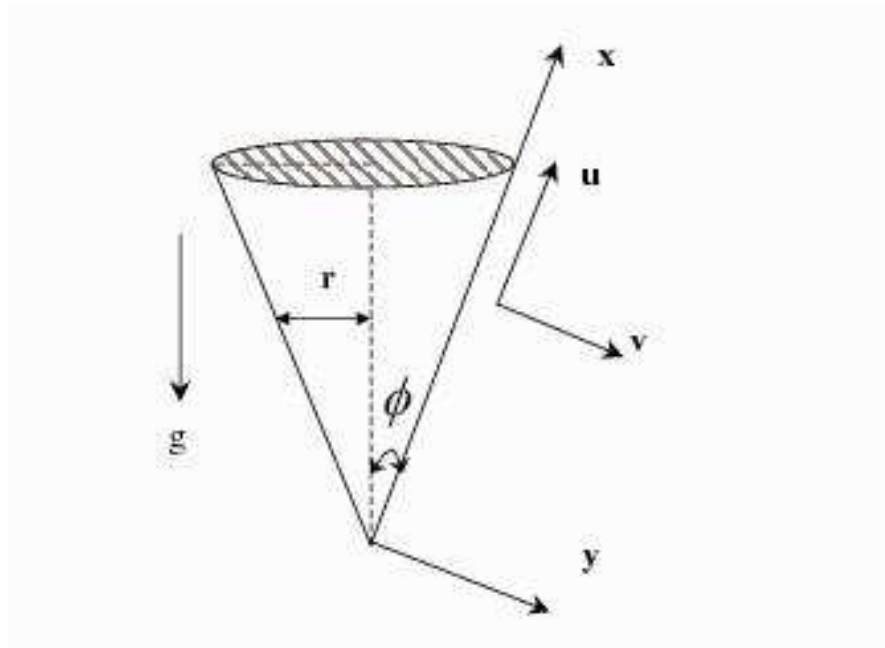

FIGURE 1. Physical model and co-ordinate system

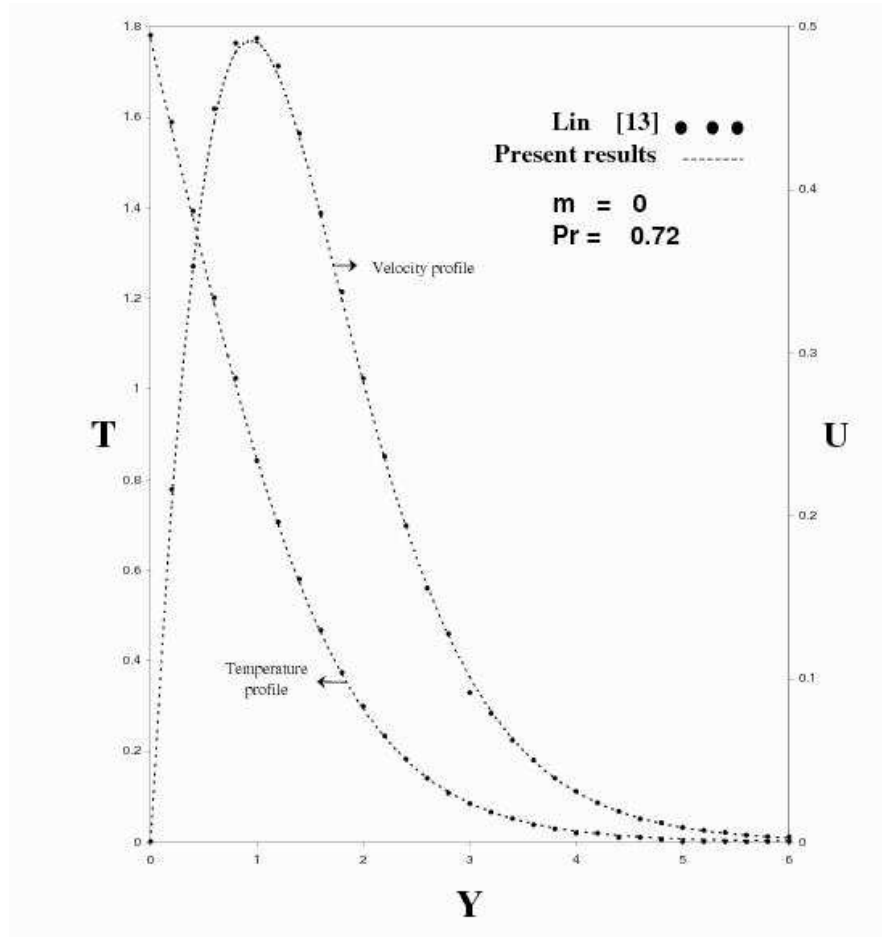

FIGURE 2. Comparison of steady state temperature and velocity profiles at  $X = 1.0$

TRANSIENT LAMINAR FREE CONVECTION FROM A VERTICAL CONE

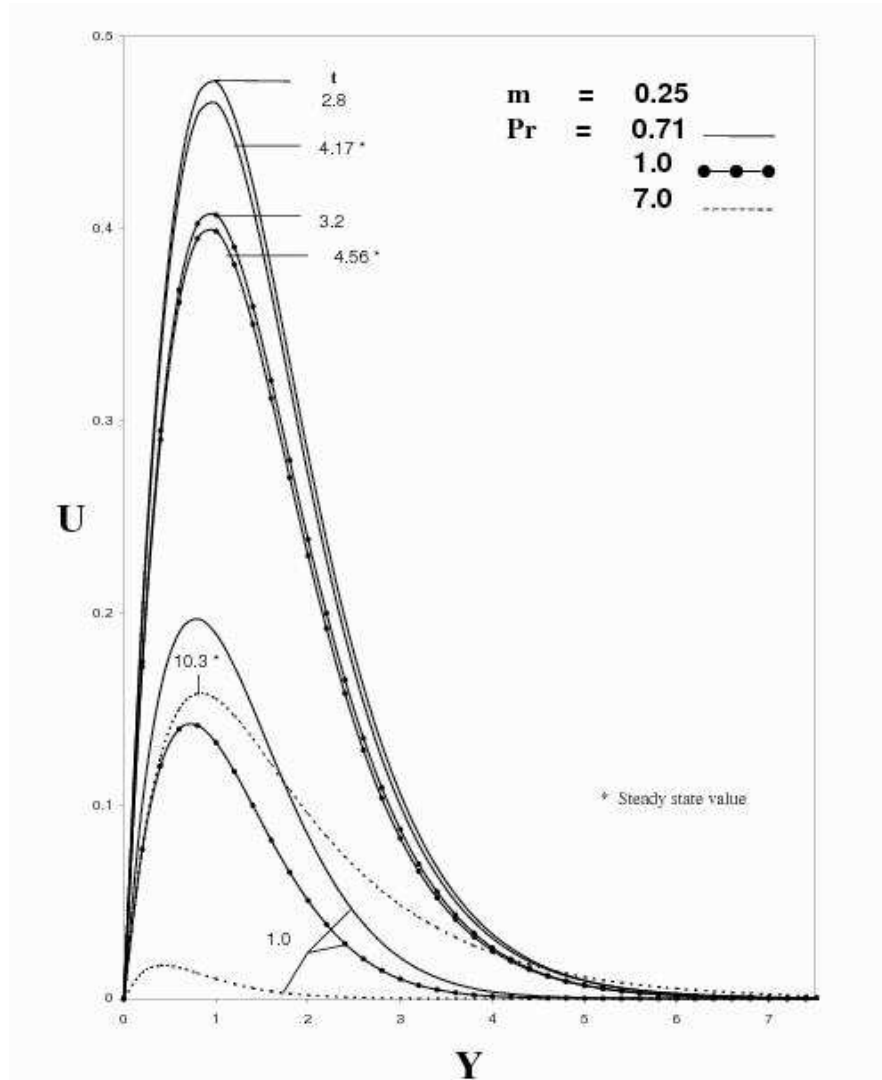

FIGURE 3. Transient velocity profiles at  $X = 1.0$  for different values of  $Pr$

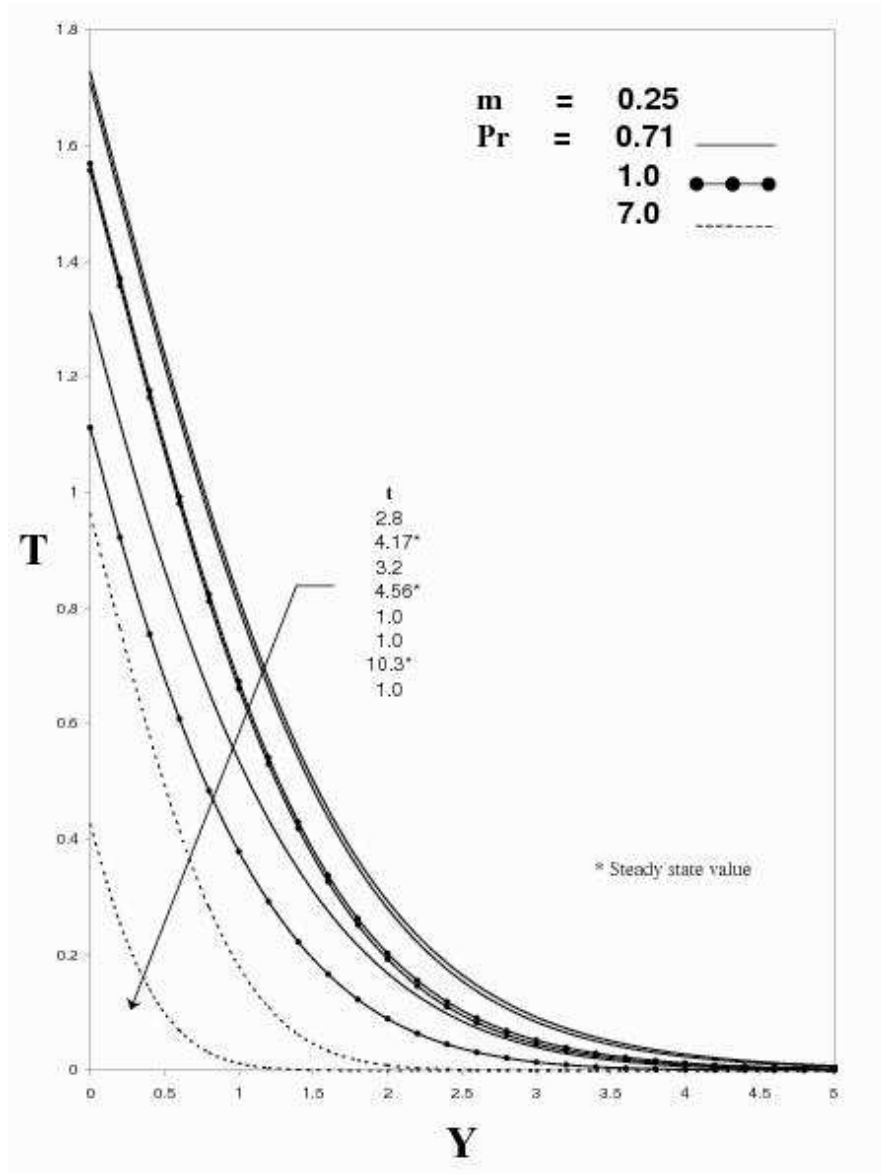

FIGURE 4. Transient temperature profiles at  $X = 1.0$  for different values of  $Pr$

TRANSIENT LAMINAR FREE CONVECTION FROM A VERTICAL CONE

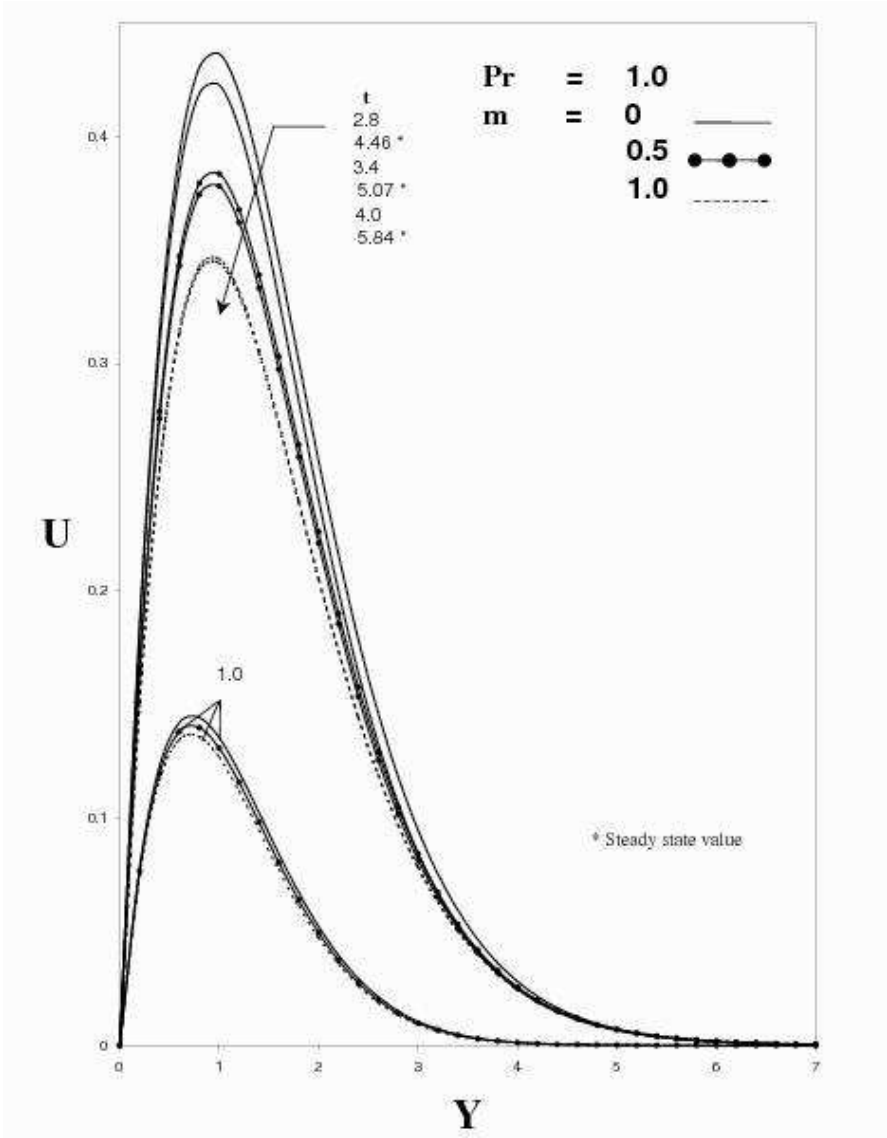

FIGURE 5. Transient velocity profiles at  $X = 1.0$  for different values of  $m$

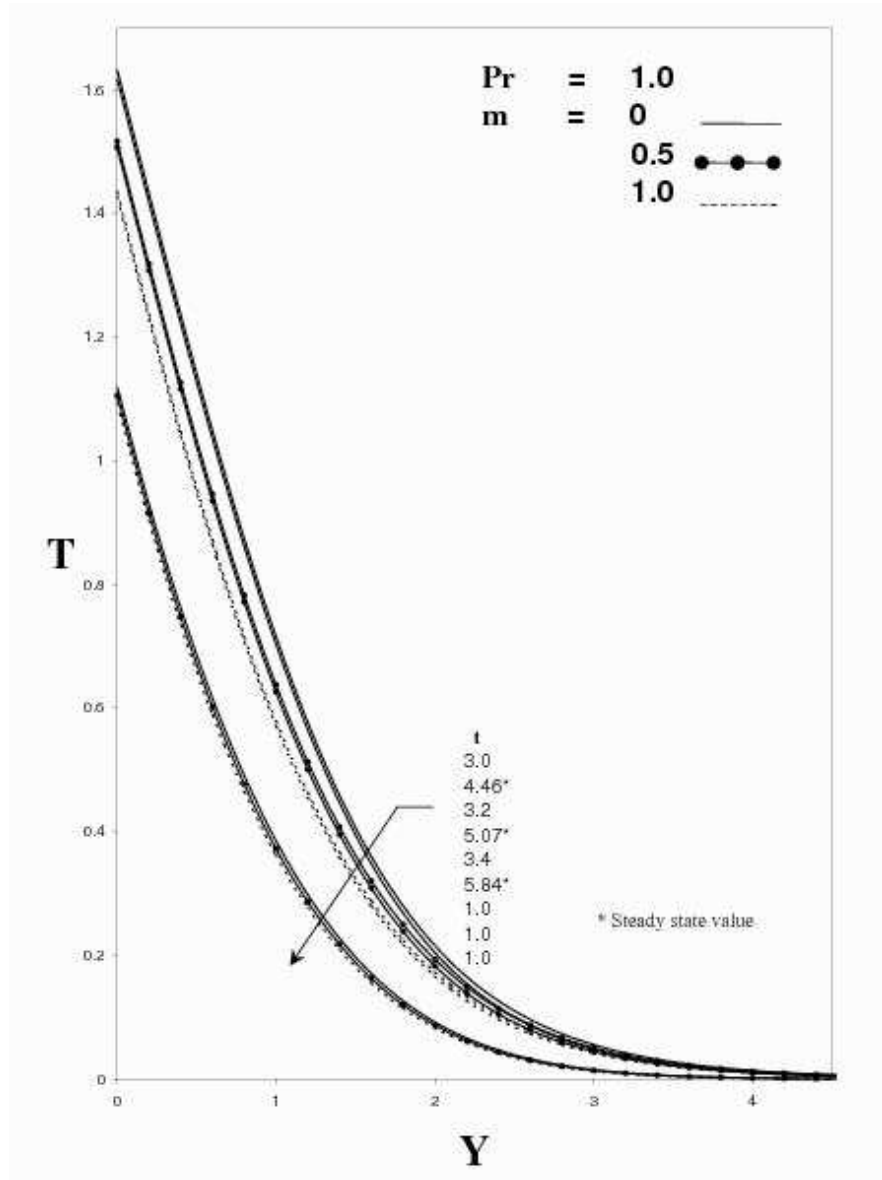

FIGURE 6. Transient temperature profiles at  $X = 1.0$  for different values of  $m$



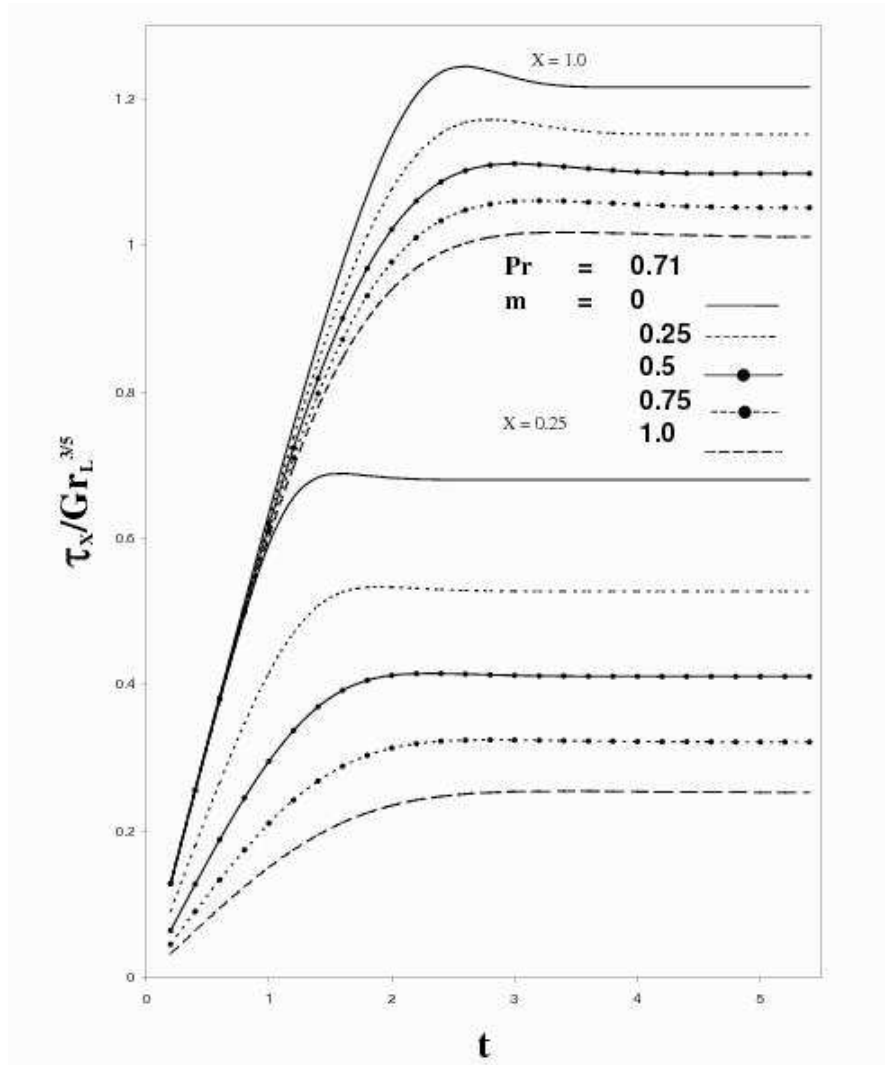

FIGURE 7. Local skin friction at  $X = 0.25$  and  $1.0$  for different values of  $m$  in transient period

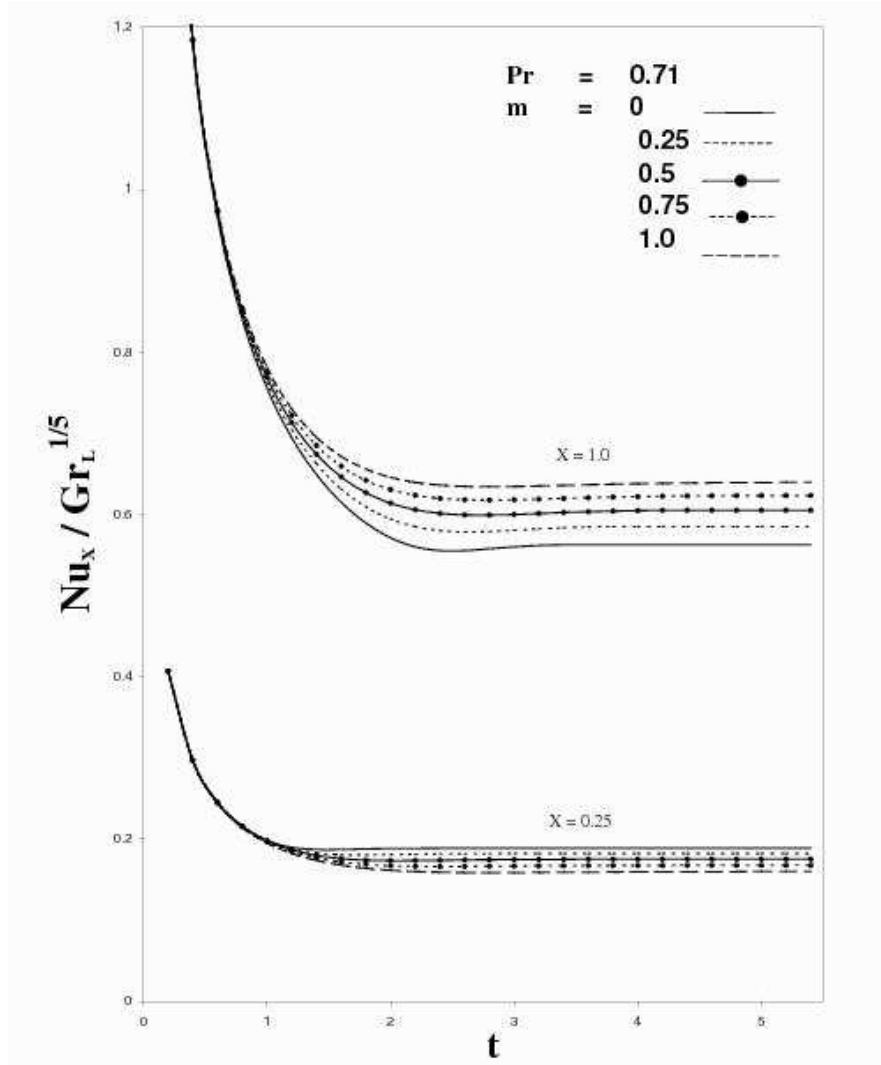

FIGURE 8. Local Nusselt number at  $X = 0.25$  and  $1.0$  for different values of  $m$  in transient period

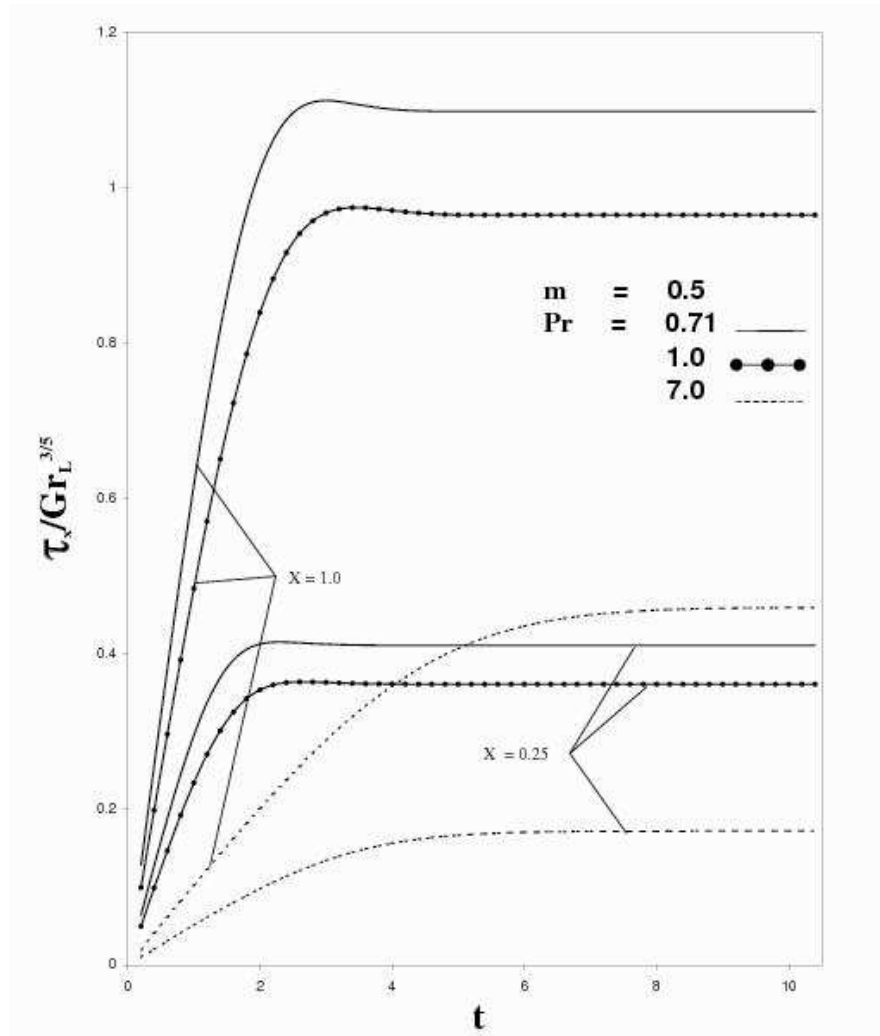

FIGURE 9. Local skin friction at  $X = 0.25$  for different values of  $Pr$  in transient period

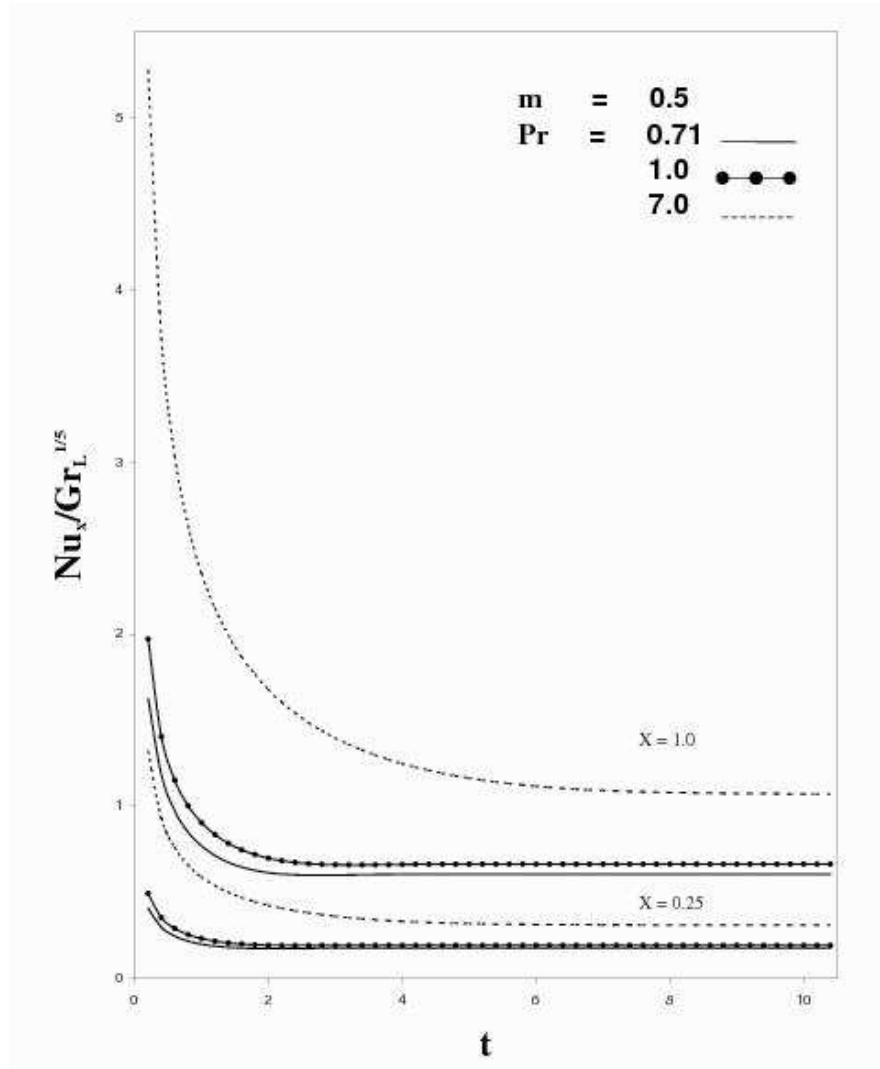

FIGURE 10. Local Nusselt number at  $X = 0.25$  and  $1.0$  for different values of  $Pr$  in transient period

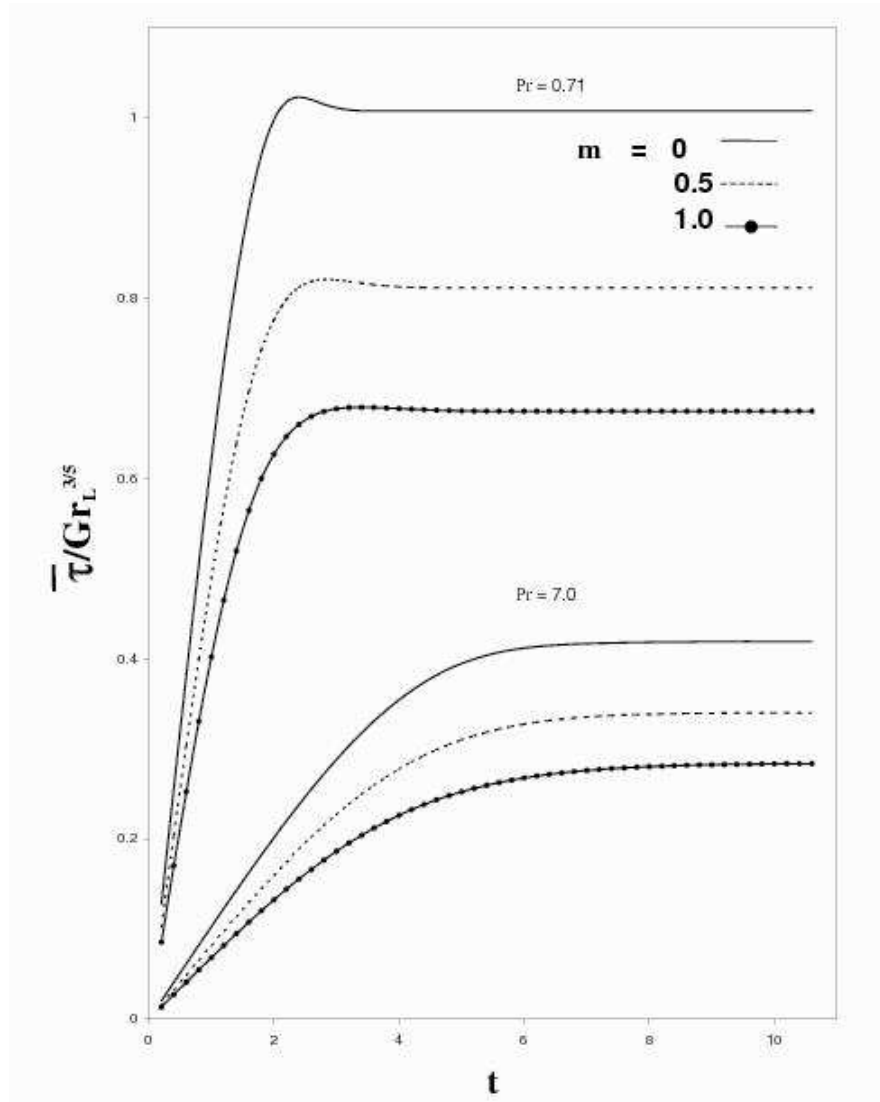

FIGURE 11. Average skin friction for different values of  $Pr$  and  $m$  in transient period

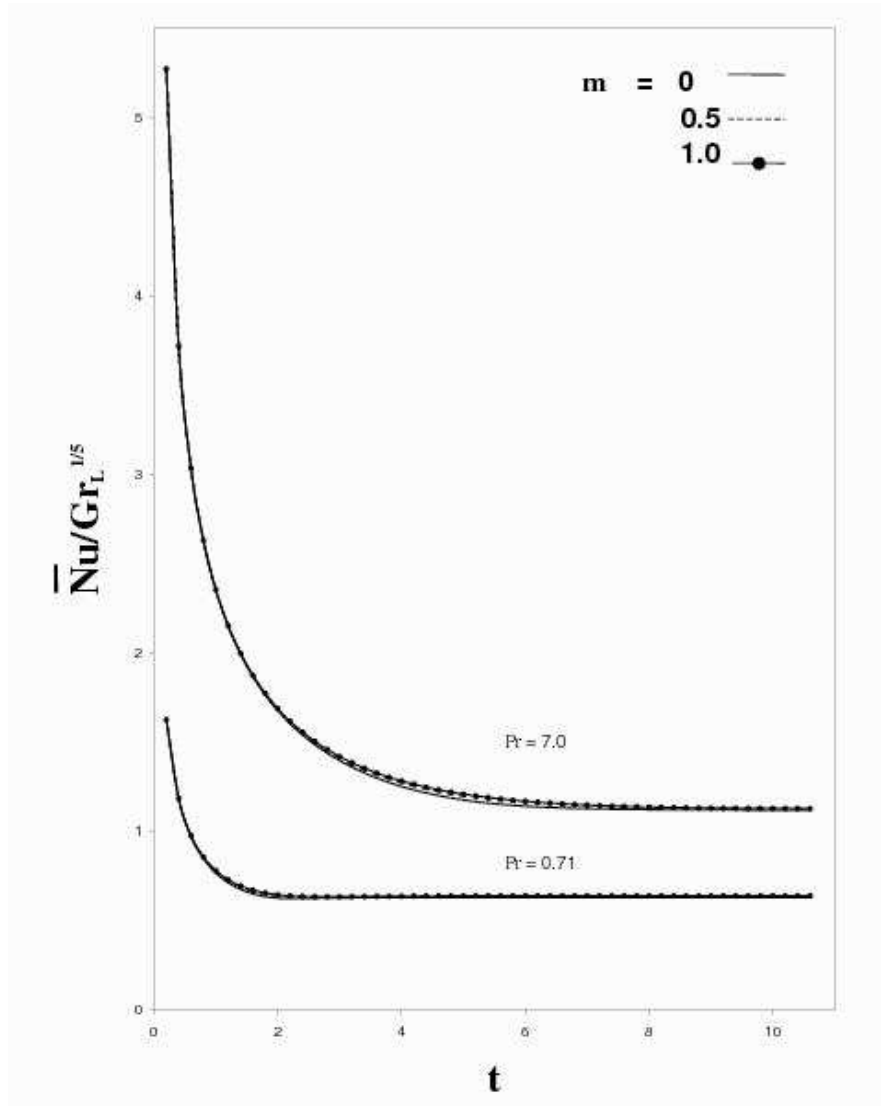

FIGURE 12. Average Nusselt number for different values of  $Pr$  and  $m$  in transient period

## References

- [1] Alamgir, M., *Overall heat transfer from vertical cones in laminar free convection: an approximate method*, ASME Journal of Heat Transfer **101**(1989), 174-176.
- [2] Carnahan, B., Luther, H. A., Wilkes J. O., *Applied Numerical Methods*, John Wiley and Sons, New York, 1969.
- [3] Chamkha, A. J., Quadir, M. M. A., *Combined heat and mass transfer by hydromagnetic natural convection over a cone embedded in a non darcian porous medium with heat generation/absorption effects*, Heat and Mass Transfer, **38**(2002), 487-495.
- [4] Ganesan, P., Loganathan, P., *Magnetic field effect on a moving vertical cylinder with constant heat flux*, Heat and Mass Transfer, **39**(2003), 381-386.
- [5] Ganesan, P., Palani, G., *Finite difference analysis of unsteady natural convection MHD flow past an inclined plate with variable surface heat and mass flux*, Int. J. of Heat and Mass Transfer, **47**(2004), 4449-4457.
- [6] Ganesan, P., Rani, H. P., *Unsteady free convection on vertical cylinder with variable heat and mass flux*, Heat and Mass Transfer, **35**(1999), 259-265.
- [7] Groşan T., Postelnicu, A., Pop, I., *Free convection boundary layer over a vertical cone in a non newtonian fluid saturated porous medium with internal heat generation*, Technische Mechanik **24**(4)(2004), 91-104.
- [8] Hasan, M., Mujumdar, A. S., *Coupled heat and mass transfer in natural convection under flux condition along a vertical cone*, Int. Comm. Heat Mass Transfer, **11**(1984), 157-172.
- [9] Hossain, M. A., Paul, S. C., *Free convection from a vertical permeable circular cone with non-uniform surface heat flux*, Heat and Mass Transfer, **37**(2001), 167-173.
- [10] Hossain, M. A., Paul, S. C., *Free convection from a vertical permeable circular cone with non-uniform surface temperature*, Acta Mechanica, **151**(2001), 103-114.
- [11] Hossain, M. A., Paul, S. C., Mandal, A. C., *Natural convection flow along a vertical circular cone with uniform surface temperature and surface heat flux in a thermally stratified medium*, Int. J. Numer. Methods Heat and Fluid Flow, **12**(2002), 290-305.
- [12] Kumari, M., Pop, I., *Free convection over a vertical rotating cone with constant wall heat flux*, J. Appl. Mech. Engng., **3**(1998), 451-464.
- [13] Lin, F. N., *Laminar convection from a vertical cone with uniform surface heat flux*, Letters Heat Mass Transfer, **3**(1976), 49-58.
- [14] Merk, H. J., Prins, J. A., *Thermal convection laminar boundary layer I*, Appl. Sci. Res., **A4**(1954), 11-24.

- [15] Merk, H. J., Prins, J. A., *Thermal convection laminar boundary layer II*, Appl. Sci. Res., **A4**(1954), 195-206.
- [16] Muthucumaraswamy, R., Ganesan, P., *On impulsive motion of a vertical plate heat flux and diffusion of chemically species*, Forsch. Ingenieurwesen, **66**(2000), 17-23.
- [17] Na, T. Y., Chiou, J. P., *Laminar natural convection over a slender vertical frustum of a cone*, Wärme und Stoffübertr., **12**(1979), 83-87.
- [18] Na, T. Y., Chiou, J. P., *Laminar natural convection over a slender vertical frustum of a cone with constant wall heat flux*, Wärme und Stoffübertr., **13**(1980), 73-78.
- [19] Na, T. Y., Chiou, J. P., *Laminar natural convection over a frustum of a cone*, Appl. Sci. Res., **35**(1979), 409-421.
- [20] Pop, I., Takhar, H. S., *Compressibility effects in laminar free convection from a vertical cone*, Appl. Sci. Res., **48**(1991), 71-82.
- [21] Pop, I., Na, T. Y., *Natural convection over a vertical wavy frustum of a cone*, Int. J. Non-Linear Mech., **34**(1999), 925-934.
- [22] Pop, I., Groşan, T., Kumari, M., *Mixed convection along a vertical cone for fluids of any Prandtl number case of constant wall temperature*, Int. J. Num. Methods Heat Fluid Flow, **13**(2003), 815-829.
- [23] Pop, I., Watanabe, T., *Free convection with uniform suction or injection from a vertical cone for constant wall heat flux*, Int. Comm. Heat Mass Transfer, **19**(1992), 275-283.
- [24] Gorla, R. S. R., Krishnan, V., Pop, I., *Natural convection flow of a power-law fluid over a vertical frustum of a cone under uniform heat flux conditions*, Mech. Res. Comm., **21**(1994), 139-146.
- [25] Ramanaiah, G., Kumaran, V., *Natural convection about a permeable cone and a cylinder subjected to radiation boundary condition*, Int. J. Engng. Sci., **30**(1992), 693-699.
- [26] Soundalgekar, V. M., Ganesan, P., *Finite difference analysis transient-free convection flow a vertical plate with constant heat flux*, 2nd Int. Conf. Num. Methods in Thermal Problems, July 07-10, Venice, Italy, **2**(1981), 1096-1107.
- [27] Takhar, H. S., Chamkha, A. J., Nath, G., *Effect of thermo-physical quantities on the natural convection flow of gases over a vertical cone*, Int. J. Engng. Sci., **42**(2004), 243-256.
- [28] Wang, T. Y., Kleinstreuer, C., *Thermal convection of micropolar fluids past two dimensional or axisymmetric bodies with suction injection*, Int. J. Engng. Sci., **26**(1988), 1261-1277.



- [29] Yih, K. A., *Uniform transpiration effect on combined heat and mass transfer by natural convection over a cone in saturated porous media: uniform wall temperature/concentration or heat/mass flux*, Int. J. Heat Mass Transfer, **42**(1999), 3533-3537.
- [30] Yih, K. A., *Coupled heat and mass transfer by free convection over a truncated cone in porous media: VWT/VWC or VHF/VMF*, Acta Mechanica, **137**(1999), 83-97.

DEPARTMENT OF MATHEMATICS, ANNA UNIVERSITY, CHENNAI, INDIA-600025

DEPARTMENT OF MATHEMATICS, ANNA UNIVERSITY, CHENNAI, INDIA-600025

FACULTY OF MATHEMATICS, UNIVERSITY OF CLUJ, R-3400, CLUJ, CP253

*E-mail address:* pop.ioan@yahoo.co.uk